



**AIR OPERATED
DOUBLE
DIAPHRAGM
PUMPS**



ISO 9001: 2008
ISO 14001: 2004

pricepumps.co.in

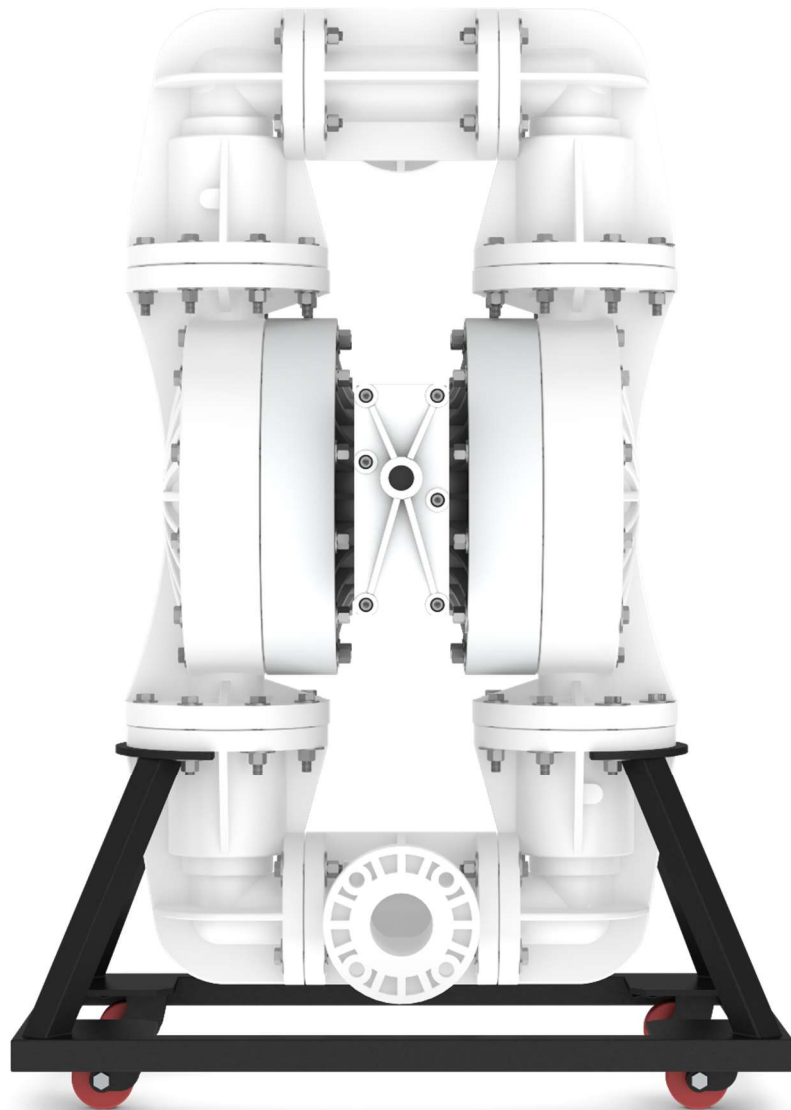

**3" POLYPROPYLENE PUMP
AOD 800 PFF PPPP/SAN/TF/P/N**

pricepumps.co.in



AIR OPERATED DOUBLE DIAPHRAGM PUMPS



ISO 9001: 2008
ISO 14001: 2004

pricepumps.co.in

SECTION 1- LEGEND

3" POLYPROPYLENE PUMP

AOD 800/PPPP/SAN/TF/P/N

MODEL: AOD 800 PFF POLYPROPYLENE

76mm (3") Pump

Maximum Flow Rate: 1024 Lpm (271 gpm)

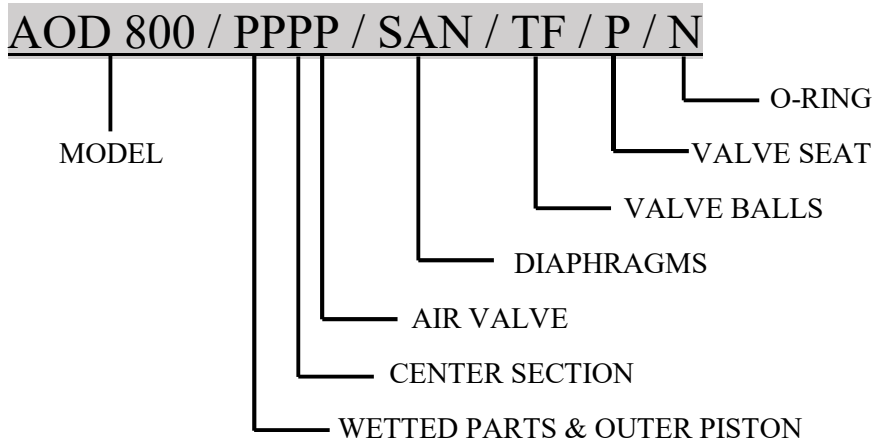

MATERIAL CODES

MODEL
AOD 800 = 3" PUMP

AIR VALVE
P = POLYPROPYLENE

VALVE BALL
TF = TEFLON

WETTED PARTS & OUTER PISTON
PP = POLYPROPYLENE /
POLYPROPYLENE

DIAPHRAGMS
SAN = SANTOPRENE

VALVE SEAT
P = POLYPROPYLENE

CENTER SECTION
P = POLYPROPYLENE

VALVE SEAT O-RING
N = NEOPRENE



AIR OPERATED DOUBLE DIAPHRAGM PUMPS



ISO 9001: 2008
ISO 14001: 2004

pricepumps.co.in

SECTION 2 – SPARE PART LIST

3” POLYPROPYLENE PUMP

AOD 800/PPPP/SAN/TF/P/N

SR No.	DISCRIPTION	PART No	QTY
1	LIQUID CHAMBER	80-1003-20	2
2	SUCTION/DISCHARGE BEND	80-2142-20	4
3	SUCTION DISCHARGE TEE	80-1202-20	2
4	NRV BALL	80-1042-55	4
5	BALL SEAT	80-1062-20	4
6	BALL CAGE	80-1092-20	4
7	MANIFOLD O RING	80-3101-51	4
8	TEE O RING	80-3146-51	4
9	SEAT O RING	80-3102-51	4
10	HOLDING PLATE	80-1111-24	2
11	LOCK NUT	80-1132-20	2
12	DIAPHRAGM	80-2042-58	2
13	BACK UP DIAPHRAGM	N/A	-
14	CENTER BLOCK	80-1302-20	1
15	CENTER BLOCK PIPE	80-1318-03	6
16	CENTER BLOCK PATTI	80-1319-03	6
17	CENTER BLOCK O RING	80-3155-56	2
18	MAIN SHAFT	80-1344-03	1
19	AIR COVER GASKET	80-3311-51	2
20	AIR COVER	80-1401-20	2
21	PILOT BUSH	80-1471-07	1
22	PILOT SHAFT	80-1454-03	1
23	PILOT SHAFT O RING	80-3176-51	8
24	PILOT SHAFT RING	80-3171-68	4
25	PILOT LOCK O RING	40-3166-51	2
26	PILOT BUSH O RING	30-3151-51	4
27	PISTON BLOCK	80-1501-20	1
28	PISTON	80-1521-69	1
29	PISTON O RING BIG	80-3201-51	1



AIR OPERATED DOUBLE DIAPHRAGM PUMPS



ISO 9001: 2008
ISO 14001: 2004

pricepumps.co.in

SECTION 2 – SPARE PART LIST (CONTINUED...)

3" POLYPROPYLENE PUMP

AOD 800/PPPP/SAN/TF/P/N

SR No.	DISCRIPTION	PART No	QTY
30	PISTON O RING SMALL	80-3224-51	7
31	PISTON RING BIG	80-3241-68	1
32	PISTON RING SMALL	80-3246-68	3
33	PISTON RING MEDIUM	80-3251-68	2
34	PISTON BLOCK CAP	80-1571-20	1
35	PISTON BLOCK CAP O RING	80-3266-51	1
36	PISTON BLOCK COVER	80-1561-20	1
37	PISTON BLOCK GASKET	80-3321-51	1
38	PISTON BLOCK COVER GASKET	80-3331-51	1
39	PISTON BLOCK PIPE	80-1586-03	2
40	EXHAUST	80-1366-23	1
41	AIR NIPPLE	50-1371-07	1
42	REDUCER	80-1377-21	1
43	CHAMBER BOLTS SS - 3/4 X 8¼ NEW	04-6063-03	24
44	SUC/DIS BOLTS SS - 5/8 X 3¼ NEW	04-6064-03	48
45	CHAMBER BOLT MS WASHER - 19.5 X 40 X 3 MM	04-6204-08	48
46	5/8 SS HEX NUT	04-6316-03	48
47	3/4 SS HEX NUT	04-6314-03	24
48	AIR COVER BOLTS SS - 3/8 X 1½	04-6002-03	12
49	AIR COVER WASHER SS - 3/8 X 30	04-6105-03	12
50	SUC/DIS/TEE WASHER SS - 16.5 X 32 X 3 MM	04-6221-03	96
51	HOLDING PLATE WASHER 19 X 35 X 3 MM	04-6217-08	1
52	P B ALLEN BOLTS SS - 3/8" X 6	04-6054-03	6
53	P B ALLEN BOLT WASHER SS - 3/8 X 11.4 X 3	04-6112-03	6
54	COMPLETE TROLLEY 800	80-1391-61	1
55	LOCK NUT NUT SMALL PVDF	80-1376-21	12
56	HOLDING PLATE BOLT SS - 3/8 X 1¼	04-6018-03	12



AIR OPERATED DOUBLE DIAPHRAGM PUMPS



ISO 9001: 2008
ISO 14001: 2004

pricepumps.co.in

SECTION 3 – EXPLODED VIEW

3" POLYPROPYLENE PUMP

AOD 800/PPPP/SAN/TF/P/N

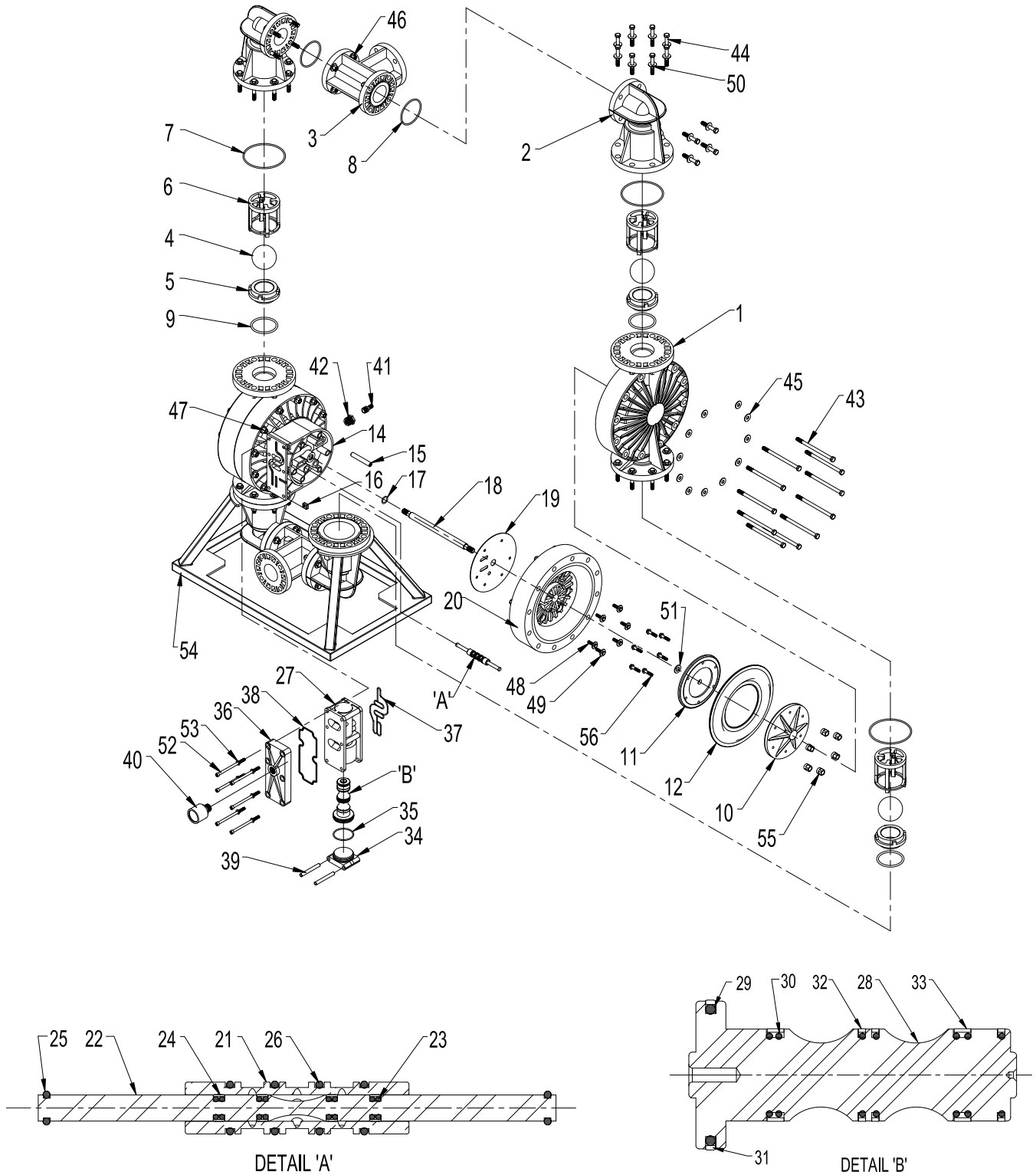



AIR OPERATED DOUBLE DIAPHRAGM PUMPS



ISO 9001: 2008
ISO 14001: 2004

pricepumps.co.in

SECTION 4 – DIMENSIONAL DRAWING

3" POLYPROPYLENE PUMP

AOD 800/PPPP/SAN/TF/P/N

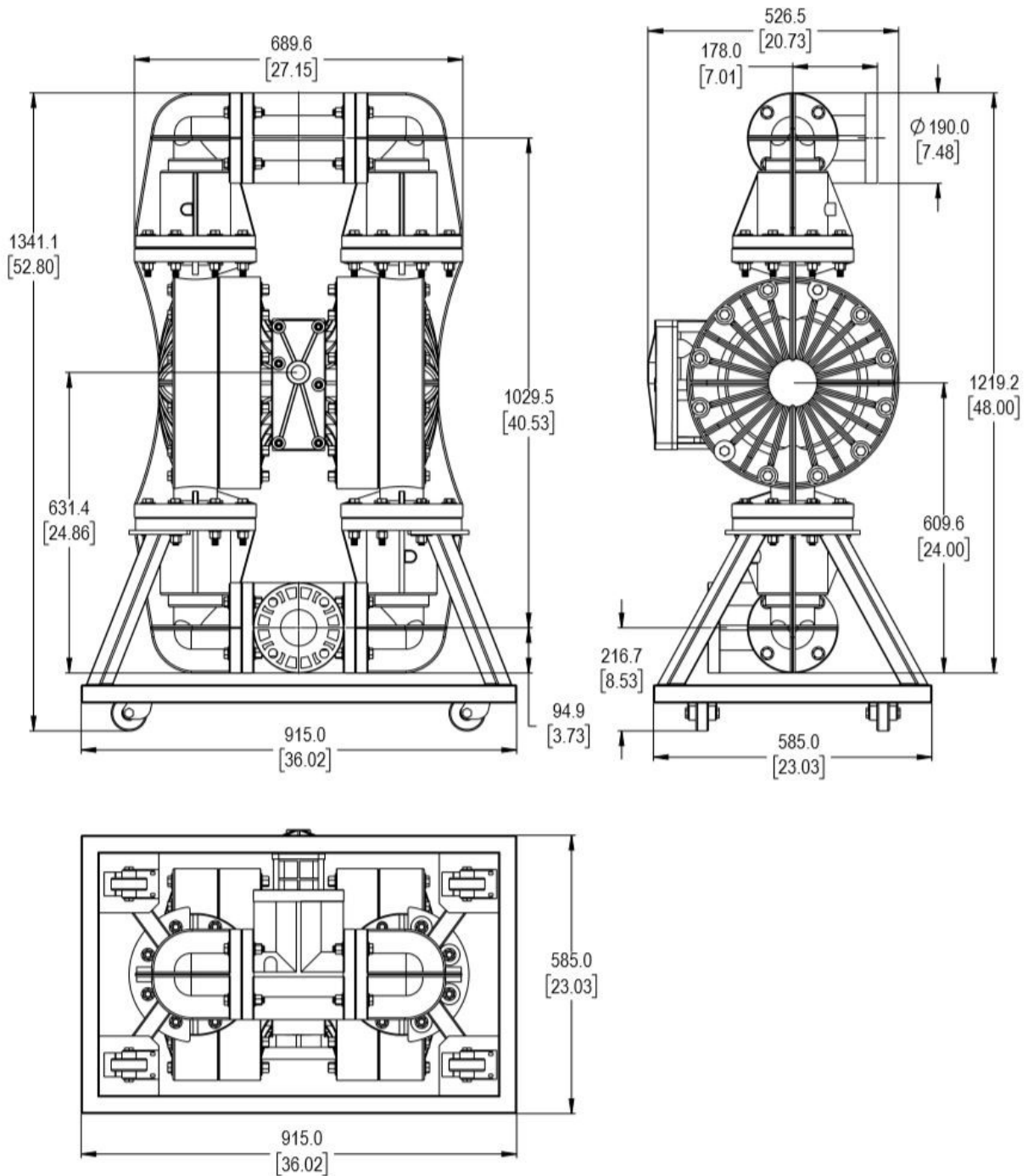



AIR OPERATED DOUBLE DIAPHRAGM PUMPS



ISO 9001: 2008
ISO 14001: 2004

pricepumps.co.in

SECTION 5 – SPECIFICATION & PERFORMANCE

3” POLYPROPYLENE PUMP

AOD 800/PPPP/SAN/TF/P/N

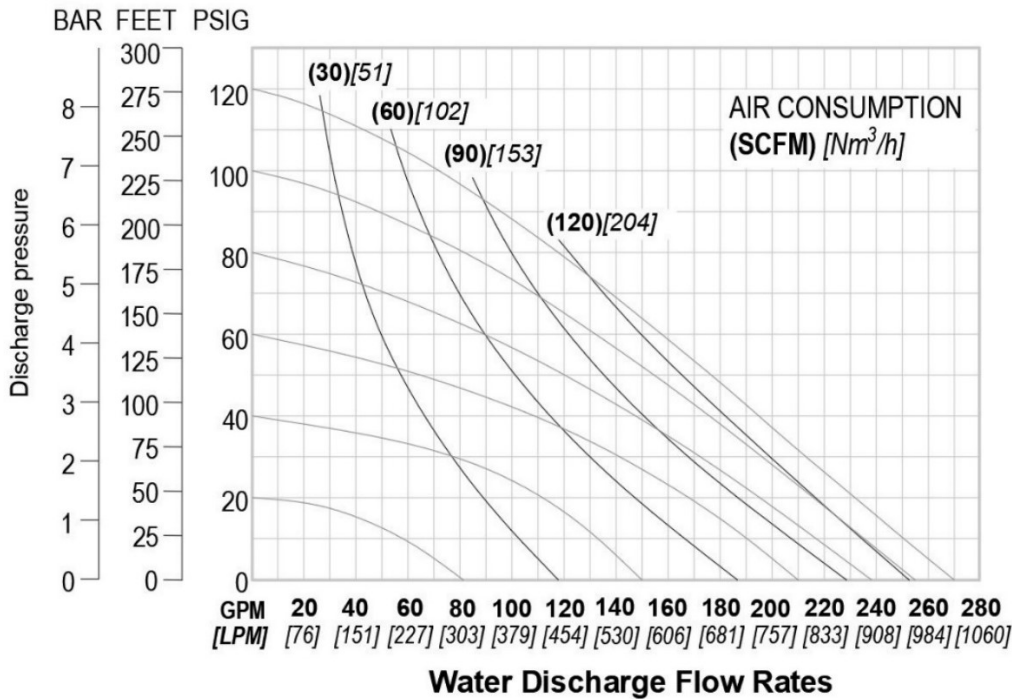

SPECIFICATIONS:

MAX FLOW RATE:	1024 Lpm (271 gpm)
MAX AIR PRESSURE:	120 psi (8.3 bar)
AIR INLET:	13 mm (1/2" BSP)
PORT INLET:	76 mm (3" BSP)
DISCHARGE:	76 mm (3" BSP)
SUCTION LIFT : DRY :	5.5 m (18.2')
WET :	8.6 m (28.4')
MAX PARTICLE SIZE:	(Dia) 12.7 mm (1/2")
AIR EXHAUST:	25.4 mm (1" BSP)

SHIPPING DIMENSIONS:

HEIGHT:	1510 mm (59.45")
WIDTH:	1030 mm (40.55")
LENGTH:	670 mm (26.38")
WEIGHT:	162 Kgs

Price Pumps meet ISO 9001-2015, ISO 14001 & CE quality standards.



**AIR OPERATED
DOUBLE
DIAPHRAGM
PUMPS**



ISO 9001: 2008
ISO 14001: 2004

pricepumps.co.in

NOTES: